

**LANGRY**®

# **LR-P6 Pull-off Tester**

## Operating Instructions





## PREFACE

Your choice of the products made by Jinan Langrui Detection Technology Co., Ltd.(Langry) is greatly appreciated. We are committed to deliver you excellent products and satisfied sales services. Please carefully read the instructions prior to use.

1. The instructions are prepared to provide the correct and complete descriptions of related products and data.

However, we do not guarantee that there are no errors or omissions. Therefore, we will not bear responsibilities for any resulting consequences.

2. Langry keeps the right of updating the instructions without prior notice.

3. Langry bears no responsibilities for possible losses from data deviation or incorrect testing conclusion arising from instrument failure and other errors.

4. When the instrument is put into operation, it means that you have carefully read and had full picture of all terms in the instructions, and you have fully agreed to all the terms in the instructions.

5. Langry will not bear responsibilities for all the signed agreements violating the statement during the sales and services process not involving Langry.





# Content

<b>1.Overview .....</b>	<b>1</b>
1.1 Application and characteristics .....	1
1.2 Specification .....	2
<b>2.Operation steps and working principle .....</b>	<b>3</b>
2.1 Instrument structure .....	4
<b>3. Intelligent Digital Pressure gauge operation description .....</b>	<b>4</b>
3.1 Digital pressure gauge inspection .....	4
3.2 Key description .....	5
3.3 Operation status .....	6
3.4 Operation status .....	6
3.5 Area parameter setting .....	6
3.6 Instrument calibration .....	7
3.7 Date correction .....	8
<b>4.Common troubleshooting .....</b>	<b>9</b>
<b>5.Safety Warning .....</b>	<b>10</b>
<b>6.Precautions .....</b>	<b>10</b>
<b>7.Package, transport, and storage .....</b>	<b>11</b>
<b>8.Accessories and Warranty .....</b>	<b>11</b>



## **1.Overview**

### **1.1 Application and characteristics**

LR-P6 Pull-off Tester (hereinafter referred to as tester) is suitable for testing the bond strength of tiles, mosaics, all kinds of plates, paints, coatings and various exterior wall building materials. This tester is an intelligent and high-precision adhesion (tensile) strength tester specially developed by LANGRY according to relevant national standards and market demand.

The main body of the detector is a portable hydraulic jack. The pressurizing device and the hollow cylinder adopt an integrated structure design, which is easy to carry and test. The Intelligent pressure gauge on the operation interface has the functions of automatic zero reset, peak holding, fast storage, undervoltage reminder, over-range display, and intelligent calibration, etc.

It adopts the integrated design of display instrument and instrument host, no need to connect the instrument, and it can be used directly after power on, which makes on-site detection more conveniently and quickly. The oil pump of the tester is driven by a lead screw and is loaded manually. Adopting a unique and innovative mechanical design, there is no need to shake the lead screw before the test. It has the characteristics of small driving torque, comfortable and reasonable shaking direction, continuous and uniform loading, stable body, etc.

Applicable standards:

JG/T 507 Digital Sticking Strength Tester

JGJ110 Testing Standard of Adhesive Strength of Tapestry Brick for Construction Engineering

JGJ126 Specification for Construction and Acceptance of Tapestry Brick Work for Exterior Wall

JGJ144 Technical specification for exterior thermal insulation on external walls

JG158 External Thermal Insulating Rendering Systems Made of Mortar with Mineral Binder and Using Expanded Polystyrene Granule as Aggregate

JG149 External thermal insulation composite systems based on expanded polystyrene

## **1.2 Specification**

Integrated design and Embedded Measurement LCD circuit

Peak holding

Pressure measurement and display (The area can be set by yourself)

Measure 10 segment date correction

Maximum test tension: 10 KN

Piston stroke: 10mm

Support span:  $\geq 120$ mm

Host weight: 2 KG

Accuracy grade:  $\leq 1.0\%$  F.S

Resolution: 0.001KN

LCD: 2.1-inch blue Segment LCD

Store measurement data (500 items)

## **2.Operation steps and working principle**

First, prepare the test piece, use tools to cut the tapestry brick into an island test piece with the same size as the standard block, and then paste the standard block on the tested test piece with super glue. After it is fully cured and glued, the tie rod assembly the standard block is well threaded, so that the pull rod passes through the hollow oil cylinder and the knob nut is tightened. Turn the handle clockwise to push the plunger in the pump body to move. The hydraulic oil communicates with the pressure sensor through the built-in oil circuit, and the other way enters the jack to push the piston up, driving the star knob nut and pull rod to apply tension to the standard block. With the rotation of the hand crank, the pulling force on the standard block gradually increases. When the facing tiles are peeled off, the oil pressure quickly drops back to zero. Since the pressure on the sensor is equal to the pressure in the jack, a force measuring device can be formed by the sensor and a digital display circuit to display the corresponding pressure value. At the moment when the facing tiles is stripped, the circuit records the maximum oil pressure value and maintains the peak display. The working process of detecting the strength of mosaics, various boards, paints, coatings and various exterior wall building materials is basically the same as the above principles. After the test, turn the handle counterclockwise to return the plunger in the pump body, and the piston will fall and reset accordingly. If the piston is not fully reset, press the piston hard to reset it.

## 2.1 Instrument structure

The tester is a whole, adopting mechatronics design and embedded measurement and display circuit. As shown below:

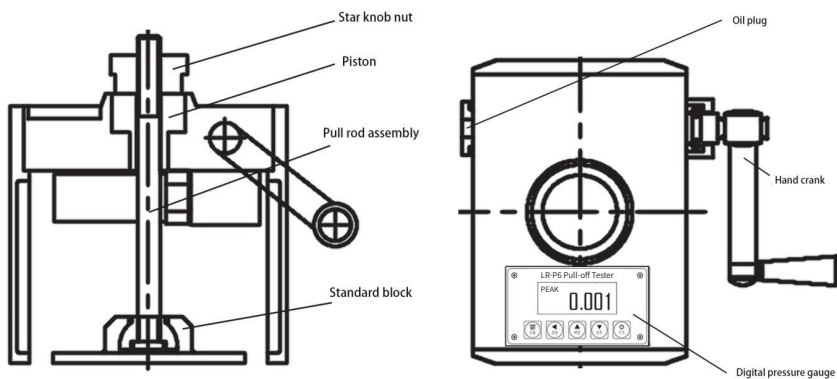



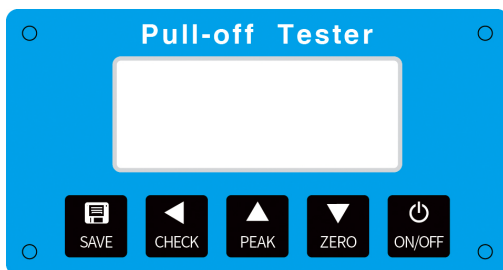

## 3. Intelligent Digital Pressure gauge operation description

### 3.1 Digital pressure gauge inspection

Press the switch button at the bottom right of the panel, and the meter will automatically jump to the force measurement interface after 2 seconds of self-checking. Low battery voltage will affect the use of the instrument. Please charge the battery in time when the LCD displays the word "LoBt". Due to the limited battery capacity, the power should be turned off in time after measurement to extend the battery life.







### 3.2 Key description

Content	Function description
	<p>Under calibration: press on the key to set the measurement as the calibration point value.</p> <p>Under setting: press on the key to save change made to parameter.</p> <p>Under measurement: press to save the pressure value.</p> <p>Under check: press to hold for 2 sec. to delete all records on pressure values.</p> <p>Under password: press to go to the calibration process if password is correct. Otherwise, it is not working.</p>
	<p>Under measurement: press on the key to start view.</p> <p>Under check: press on the key to return to measurement.</p> <p>Under password and setting: move the modified bit under change.</p>
	<p>Under measurement: enable or disable the peak status (long press).</p> <p>Under measurement: Switch measurement unit (short press).</p> <p>Under check: go to view the previous record.</p> <p>For parameter change under password and setting: increase the parameter changed.</p>
	<p>Under measurement: press and hold for 2 sec. to clear measurements, and set the current measurement as zero</p> <p>Under check: go to view the next record.</p> <p>For parameter change under password and setting: decrease the parameter changed.</p>
	<p>Under any circumstance: press on the key to switch on/off the instrument.</p>

### 3.3 Operation status



The instrument provides 5 display statuses, which are appropriately marked in the top left corner of LCD, i.e., measurement, check, password, parameter, and calibration.

### 3.4 Operation status

- ◇ Press  to switch from the measurement to check, or vice versa.
- ◇ Under measurement, in case that the measured value is beyond “99999”, “-oL” will show.
- ◇ Under measurement, press on  to clear the measurements, and set the current measurement as zero.
- ◇ It is possible to view all records by means of press on   under check.
- ◇ Press and hold  for 2 sec. under view to delete all recorded data and return to the measurement.
- ◇ The battery of this machine is 4.2V lithium battery. Please use the supplied adapter and connect the charging plug to the charging hole on the side of the instrument when charging.

Note: Deleted data cannot be restored, please operate with caution

### 3.5 Area parameter setting





The area parameter modification is controlled by a password. Area parameter modification status can only be accessed to with a correct password. Carry out shutdown to exit the system in response to entrance by mistake! Modification steps: press and hold the  key to turn on the password to enter the password state, enter the password “1234”, then press the  key to enter the area setting interface, select the corresponding area code in the table below, and then press the store key to save and return to the measurement state.



Code	Unit/Area
No	KN (Factory Default)
F0	MPa/KN Conversion, 100x100mm
F1	MPa/KN Conversion, 45x95 mm
F2	MPa/KN Conversion, 40x40mm
F3	MPa/KN Conversion, $\Phi$ 50mm
F4	MPa/KN Conversion, custom area (cm <sup>2</sup> )

### 3.6 Instrument calibration

Calibration setting is protected by password. Pressure calibration status can only be accessed to with a correct password. Carry out shutdown to exit the system in response to entrance by mistake!







Step: ① Access the password status by pressing to hold the  key, and then enter password 1111. Press  to enter into the calibration status. ②The instrument provides “0%” indication at the top row. Now, ensure that the instrument is not pressurized, and the standard dynamometer reading is zero. The instrument provides “100%” reading at the top row in response to press on  . Now, start pressurization with hand pump until the standard dynamometer reading arrives at the full-scale pressure of the instrument. Press the  key to complete calibration at 100% scale point. After calibration, the instrument automatically exits the calibration status. The calibration accuracy can be maintained despite power-off. Repeat the steps above if the accuracy re-measurement is still unsatisfied, or carry out the segment data correction (Section 3.7). Since the instrument adopts high-precision sensors and high-precision AD chips, the measurement data has a good linearity. Generally, it can meet the requirements of conventional detection without date correction. Therefore, the functional description

of the date correction can be ignored.

◇ Do not care about the value displayed at the bottom of the LCD when calibrating.

### 3.7 Date correction

Principle of data correction: when the sensor input signal arrives at the instrument, make comparison with the standard conversion value at each data point in the line chart in the order of conversion values, and then obtain corresponding measured value at the line chart in the appropriate zone. Following the calibration of measured value, automatically start the data correction.

Similarly, the broken line correction is also controlled by the password. Press and hold the  key to start up and enter the password state. Under password status, enter 3333, and press on storage key to go to the data correction status. A data point requiring correction in any zone is available by   key. Start pressurization with hand crank. When the pressure value corresponds to a data point, press on  key to save the current data point. The tester is configured for a full-scale of 10KN. In response to data correction in a range of 1-2KN, the instrument shows 0% after accessing the data correction status. Press on the  key to vary to 10%. Start pressurization to 1KN in the standard dynamometer. Press on the  key, and the instrument shows 20%. Then, start pressurization to 2KN in the standard dynamometer, and press on the  key. Now, reboot the instrument to end correction.

#### 4.Common troubleshooting

Failure	Causes	Solutions
No pressure reading in pressure gauge	Oil shortage in oil pump	Unscrew the oil plug and refuel
	Pressure gauge damage	Remove for inspection or recalibration
Expected pressure not reached or down too fast	Oil shortage in oil pump	Unscrew the oil plug and refuel
	Plunger or piston leaking oil	Check and replace the sealing ring
	Use of incorrect oil or contaminated oil	Oil change
Pressure gauge disorder, large deviation of the measured value	Pressure gauge setting error or calibration operation error	Enter the password state, enter "9898" to restore factory settings

## **5.Safety Warning**

1. The Pull-off Tester operators shall have full understanding of the instrument structure, and carefully read the manual before use.
2. Stop operation to make check should leak is found during operation. Carry out troubleshooting before reuse.
3. Clean 10 # aviation hydraulic oil or N32 # anti-wear hydraulic oil shall be filled in the engine body. Fill up the oil completely and let the piston rise and fall repeatedly to expel the air.

## **6.Precautions**

1. Overload is strictly prohibited and can only be used up to 10kN. Otherwise, permanent damage may occur.
2. Keep the hydraulic system clean. After use, turn the crank counterclockwise to retract the piston.
3. Put the tester on a solid ground so that it can sustain pressure vertically. Operation beyond the specified stroke is prohibited.
4. Fill with clean hydraulic fluid.

## **7.Package, transport, and storage**

The tester is packaged in a plastic sealed box. together with operation manual, certificate of conformity, packing list, attachments, etc. Please carefully check to avoid omission. The tester in container may be shipped in the common mode of transport. Provisions shall be made to prevent overspill and exposure to bad weather during shipment. Store the tester in a well-ventilated place free of exposure to bad weather.

## **8.Accessories and Warranty**

The tester is typically delivered complete with:

1. One tester host
2. One hand crank
3. One set of pull rod assembly
4. Two sets of pull-off standard block
5. One certificate of conformity and one operation manual

The product is guaranteed for one year under the specified conditions of use and maintenance for life. If there is a problem with the product, please contact our client service in time.

## **Manufacturer warranty**

Langry guarantees that the tool is free from defects in materials and manufacturing processes when it leaves the factory, and the warranty is valid only if the user correctly installs, operates, maintains and cleans the tool in accordance with Langry's operating instructions.

The warranty covers the free replacement or repair of damaged parts during the whole service life of this tool. If the parts need to be repaired or protected due to normal wear and tear, they are not covered by the warranty.

Other claims are not covered by the warranty unless there is a different provision under the specific law of the customer's country. In particular, langry shall not be liable for any direct, indirect, incidental or inevitable damage, financial loss or additional expenses caused by or related to the improper use or abuse of this tool. Expressly exclude implied warranties of merchantability and fitness for a particular purpose.

In case of repair or replacement, the tool or relevant parts shall be sent to Langry's market organization immediately after the failure is determined.



V1.2

JINAN LANGRUI DETECTION TECHNOLOGY CO.,LTD

✉ [langry@jnlrkj.com](mailto:langry@jnlrkj.com)  [www.langryndt.com](http://www.langryndt.com)